

**PERFORMANCE ANALYSIS OF SLIDING WINDOW MULTIUSER
DETECTORS USED IN ASYNCHRONOUS DS-CDMA SYSTEMS**

تحليل أداء الكاشفات متعددة المستخدمين ذات النافذة المنزلقة المستخدمة في أنظمة الاتصال غير المتزامنة ذات التقسيم متعددة الشفرات ذات التتابع المباشر

Mohamed Samy*, Mohamed El-Dakiky*, and Islam Shaalan*

الخلاصة باللغة العربية:

في هذا البحث يتم تطبيق طريقة النافذة المنزلقة على كل من كاشفات فك الارتباط متعددة المستخدمين وكاشفات خطية متعددة المستخدمين ذات أقل متوسط لمربعات الخطأ. ويتم استنتاج احتمالات الخطأ لهذه الكاشفات التي تستخدم في نظام الاتصال غير المتزامن ذو التقسيم متعدد الشفرات وفي وجود تشويش له شكل Gaussian وبيئة ملاشبية متعددة المسارات. الكاشفات المقترحة تقوم بتقسيم الإشارة المستقبلية إلى نوافذ معالجة وتقوم بمعالجتها نافذة تلو الأخرى. ويتم دراسة تأثير توسيع نافذة المعالجة على احتمالات الخطأ. ومن خلال الاستنتاجات السابقة يتضح أن كاشف فك الارتباط له خطأ أداء أفضل من الكاشف الخطي ذو أقل متوسط لمربعات الخطأ عندما تكون قدرة المستخدمين المتداخلين أعلى من قدرة المستخدم المرغوب. أيضا نجد ان أداء الكاشفات السابق نكرها يتحسن أداءها بشكل واضح عند زيادة طول نافذة المعالجة لأربعة رموز.

ABSTRACT

In this paper, the sliding-window method is applied on both decorrelating and linear minimum mean-squared error (LMMSE) multiuser detectors. The analytical expressions for the error probability of those multiuser detectors (MUDs) are derived. The analysis is presented for asynchronous direct sequence code-division multiple-access (DS-CDMA) in additive white Gaussian noise (AWGN) and multipath fading environment. The adopted detectors divide the received signal stream into processing-windows and process them window by window. The effects of expanding the processing-window length on the error probabilities are investigated. The analysis shows that the error performance of the decorrelating detector is much better than that of the LMMSE detector when the power of the interfering users is larger than the desired user power. It is also shown that the performance of the presented detectors will be significantly improved with processing-window length up to four symbols.

KEYWORDS: decorrelating detectors, AWGN, LMMSE, MUD, RAKE, NF problem.

* Electrical Engineering Dept., Faculty of Engineering at Port Said, Suez Canal University, Egypt.

1. INTRODUCTION

Next generation communication systems have been developed to support voice, data, and multimedia services with large system capacity [1]. A direct sequence code-division multiple-access (DS-CDMA) scheme has been chosen as a multiple access technique for next generation communication system. A conventional matched filter (MF) detector for DS-CDMA systems is limited for single user detection [2],[3]. To overcome such a limitation, multiuser detectors MUDs have been investigated for next generation communication systems. MUDs have been proposed to alleviate the performance degradation caused by multiple-access interference (MAI) in CDMA. In MUD, the received signal is matched-filtered by spreading sequence corresponding to each user and then processed by multiuser filter. For synchronous systems, the multiuser detection is achieved by processing the received signal over the present symbol duration. However, for asynchronous systems, the optimal multiuser detection needs an infinitely long processing-window [2]. These infinite memory length detectors are almost impossible

to implement due to its computational complexity, memory requirements, and processing delay. For this reason, suboptimal multiuser detectors for asynchronous channels usually adopt the linear time invariant (LTI) filtering method [3], [4], finite memory-length (referred to FIR) method [2], [3], one-shot sliding-window method [3], [5-7], or isolation bit insertion method [3] to obtain truncated infinite memory length detectors. However the LTI filtering and finite memory-length (FIR) methods require large computational complexity [2], [3], one-shot sliding-window method doesn't exhibit satisfactory performance [3], [5]. In addition, the isolation bit insertion method has low bandwidth efficiency [2]. Therefore, in this paper, we generalize the sliding-window technique to utilize more than one symbol. The sliding-window technique is applied on both decorrelating and linear minimum mean-squared error detectors (LMMSE) as linear MUDs. The decorrelating and LMMSE detectors have received the most interest due to their good performance and simple mathematical

formulation [15]. The decorrelating and LMMSE detectors can be characterized as an inverse of some form of correlation matrix [8].

In this paper, sliding-window decorrelating and LMMSE detectors are mathematically developed. It is shown that when extending the processing-window length, the error probability will be greatly reduced.

The paper is organized as follows. In section 2, the system model and channel characteristics are presented. Sliding-window technique is described in section 3, and Multiuser detectors in multipath fading channel are presented in section 4. Section 5 presents the performance analysis of the proposed detectors. Section 6 presents the numerical results, and, finally, conclusions are drawn in section 7.

2. SYSTEM MODEL AND CHANNEL CHARACTERISTICS.

A. System Model.

The CDMA system consists of K users. These K users share the same communication media asynchronously.

The channel of each user is modeled as frequency selective fading channel with L resolvable paths. The fading characteristic for each path is independent and identically distributed. It is assumed that the fading rate is slow enough to regard the channel characteristic as a constant over one symbol duration T_s .

The received signal $r(t)$ is the convolution of the transmitted signal and the channel impulse response plus the common additive channel noise. Then received signal can be represented as follow [15]:

$$r(t) = \sum_{n=0}^{N_s-1} \sum_{k=1}^K A_k b_k^{(n)} s_k(t - nT_s) * C_k^{(n)}(t) + w(t), \quad (1)$$

where N_s is the number of symbols in the data packet, K is the number of active users, $A_k = \sqrt{P_k}$ is the transmitted amplitude of user k (assumed to be constant over the transmission), P_k is the transmitted power of user k , $b_k^{(n)}$ is the n th transmitted data symbol of user k ,

$s_k^{(n)}(t) = s_k(t - nT_s)$ is the k th user spreading sequence waveform, $C_k^{(n)}(t)$ is the impulse response of the k th user's radio channel at symbol interval n , $*$ denotes convolution and $w(t)$ is the

complex zero-mean additive white Gaussian noise (AWGN) with variance σ^2 . For convenience, assume that $s_i^{(n)}(t)$ is real and normalized so that $s_i^{(n)}(t) = 0 \quad \forall t \notin [nT_s, (n+1)T_s]$ and $\int_{nT_s}^{(n+1)T_s} s_i^{(n)}(t)^2 dt = 1$,

where T_s denotes the symbol interval, and $C_k^{(n)}(t) = \sum_{l=1}^L c_{k,l}^{(n)} \delta(t - \tau_{k,l})$

where $c_{k,l}^{(n)}$ is the complex coefficient of the l th path of user k during the n th symbol interval,

and $\tau_{k,l}$ is the delay of the l th multipath component of user k . Now the received signal can be written as

$$r(t) = \sum_{n=0}^{N_s-1} \sum_{k=1}^K \sum_{l=1}^L A_k h_k^{(n)} c_{k,l}^{(n)} s_k(t - nT_s - \tau_{k,l}) + u(t) \quad (2)$$

for notational convenience. Eq. (2) may be expressed in vector form as follow,

$$r(t) = \sum_{n=0}^{N_s-1} S^{(n)} h^{(n)} + W \quad (3)$$

where $S^{(n)} = [s_1^{(n)} \ s_2^{(n)} \ \dots \ s_K^{(n)}]$ is the spreading sequence vector with $s_k^{(n)} = [s_{k,1}^{(n)} \ s_{k,2}^{(n)} \ \dots \ s_{k,L}^{(n)}]$, where $s_{k,l}^{(n)} = s_k(t - nT_s - \tau_{k,l})$, $h^{(n)} = C^{(n)} A \ b^{(n)}$, where $C^{(n)} = \text{diag}[C_1^{(n)} \ C_2^{(n)} \ \dots \ C_K^{(n)}]$ is the complex channel coefficient matrix

with $C_k^{(n)} = [c_{k,1}^{(n)} \ c_{k,2}^{(n)} \ \dots \ c_{k,L}^{(n)}]^T$ where $[.]^T$ denotes the transpose notation, $A = \text{diag}[A_1 \ A_2 \ \dots \ A_K]$ is the matrix of total transmitted amplitudes, $b^{(n)} = [b_1^{(n)} \ b_2^{(n)} \ \dots \ b_K^{(n)}]^T \in \Xi^K$ is assumed to be Gaussian random data vector with modulation alphabet Ξ and W is the channel noise vector. If the received signal $r(t)$ is fed into a correlation receiver that is matched to the corresponding spreading waveforms, the output signal vector can be represented as follow [2], [3], [4],

$$y^{(n)} = R(-1)h^{(n+1)} + R(0)h^{(n)} + R(1)h^{(n-1)} + W^{(n)} \quad (4)$$

where

$$R_{k,l}(l) = \int_{-\infty}^{\infty} s_j(t - \tau_j) s_k(t + lT_s - \tau_k) dt = 0 \quad \forall |l| > 1 \quad (5)$$

$$R_{j,j}(0) = 1, R_{j,j}(1) = 0 \text{ and } R(-l) = R^T(l)$$

and the covariance matrix of the correlated noise $W^{(n)}$ is given by $\sigma^2 R(0)$. The conventional RAKE detector makes decision on the combined output of the correlation receiver. There are L resolvable independently faded paths. These L paths are coherently combined to form decision statistic

$$b_r^{(n)} = \text{sgn} \{ C^{H(n)} y^{(n)} \}, \quad (6)$$

where H denotes the Hermitian notation.

B. Channel Characteristics.

The channel coefficients vector $C = [C^{(0)} C^{(1)} \dots C^{(N_k-1)}]^T$, (7) is assumed to be complex Gaussian random vector with zero mean and covariance matrix Σ_c . It is assumed that the fading channel coefficients have a zero mean and variance normalized to the covariance so that $\sum_{i=1}^L E\{|c_{k,i}^{(n)}|^2\} = 1, \forall k$.

The standard wide-sense stationary uncorrelated scattering (WSSUS) fading channel model holds [9]. The channels are assumed to be stationary over the observation interval so that the channel autocorrelation 'autocovariance' function $\varphi_{c_{k,i}}(n, n') = E\{c_{k,i}^{(n)} c_{k,i}^{(n')*}\}$ is a function of the time difference $(n - n')T$, only [9], [10]. The stationary assumption is valid if the vehicle speed doesn't change during transmission. The Doppler power spectrum is assumed to be classical Jake's spectrum [9], [11], [12]. The width of the channel autocorrelation function is called channel coherence time, denoted by $T_{coh} \approx 1/f_d$, where f_d is the maximum Doppler spread. The channel is said to be *slowly fading* if $T_{coh} \gg T_c$ and *fast*

fading if $T_{coh} < T_c$. In the intermediate case $T_{coh} > T_c$, the channel will be termed *relatively fast fading*. In this paper, the channel of each user is modeled as frequency selective slow fading channel. The uncorrelated scattering assumption is valid if the channel coefficients are independent. The covariance matrix of the channel can be partitioned as

$$\Sigma_c = \begin{bmatrix} \Sigma_{c^{(0)}} & \Sigma_{c^{(0)c^{(1)}}} & \dots & \Sigma_{c^{(0)c^{(N_k-1)}}} \\ \Sigma_{c^{(1)c^{(0)}}} & \Sigma_{c^{(1)}} & \dots & \Sigma_{c^{(1)c^{(N_k-1)}}} \\ \vdots & \vdots & \ddots & \vdots \\ \Sigma_{c^{(N_k-1)c^{(0)}}} & \Sigma_{c^{(N_k-1)c^{(1)}}} & \dots & \Sigma_{c^{(N_k-1)c^{(N_k-1)}}} \end{bmatrix}, \quad (8)$$

with WSSUS channel model $\Sigma_{c^{(n)}} = \text{diag}[\Sigma_{c_1^{(n)} c_1^{(n)}} \Sigma_{c_2^{(n)} c_2^{(n)}} \dots \Sigma_{c_k^{(n)} c_k^{(n)}}]$, (9) where $\Sigma_{c_k^{(n)} c_k^{(n)}} = \text{diag}\{\varrho_{k,1}(n, n) \varrho_{k,2}(n, n) \dots \varrho_{k,L}(n, n)\}$

3. SLIDING-WINDOW MODEL.

To explain the basic concepts of the proposed MUDs, we consider a multi-user system with 3 users only and single path propagation. FIR-MUD is an approximation of IIR-MUD with finite memory length [2], [10], as shown in Fig.1.a. FIR-MUD with window length "P" utilizes PKL MFs. (PKL is the multiplication of P, K and L)

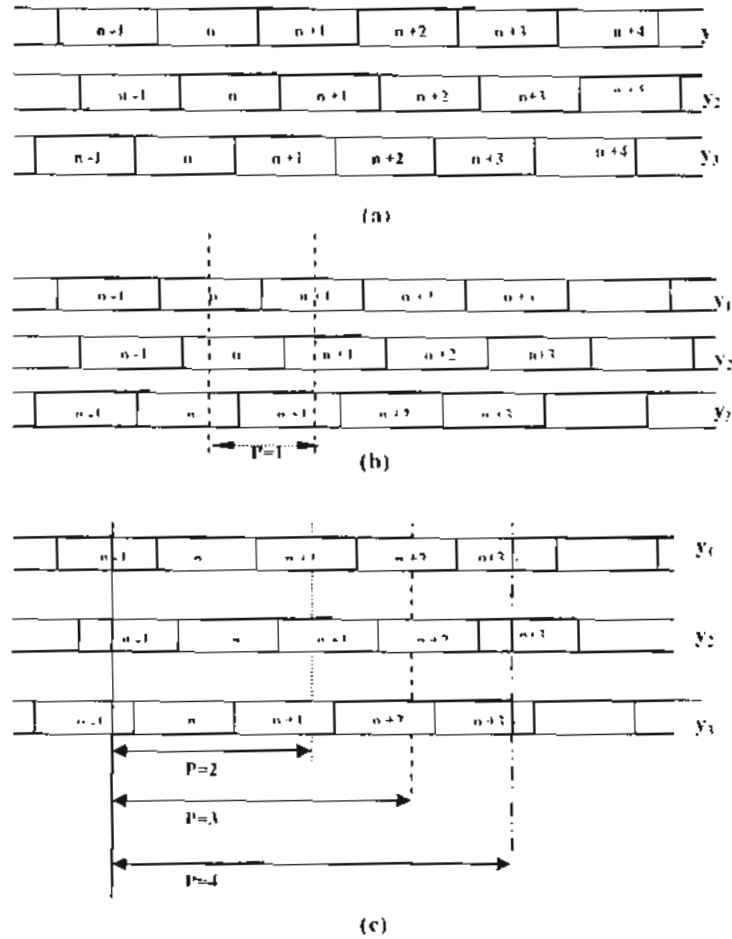

(a) FIR approximation $P=6$. (b) IOS approximation $P=1$. (c) Sliding window approximation $P=2, 3, 4$.

Fig. 1. Timing diagram

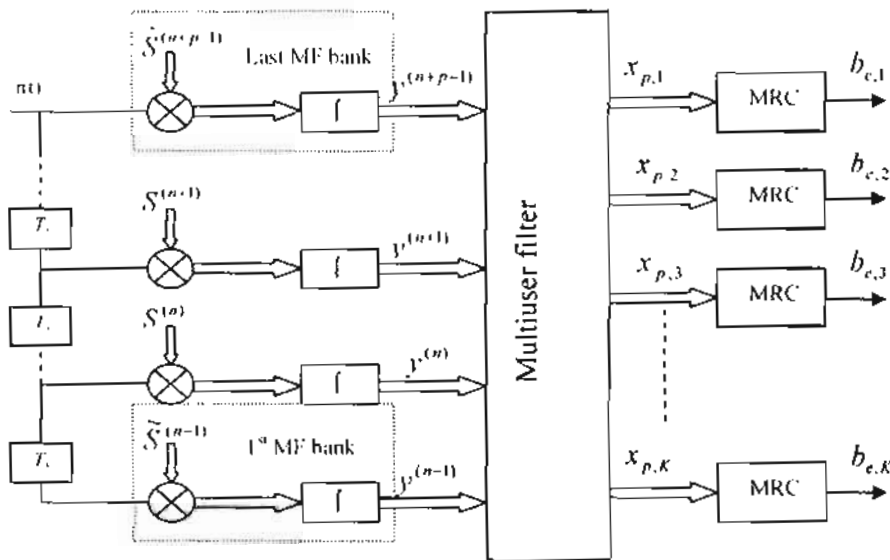

Fig. 2. Block diagram of the sliding window MUD

The performance of FIR-MUD may be degraded due to edge effect [2], [3].

Fig.1.a. shows that the $(n+1)$ th symbol of user 1 has edge effect on $(n+3)$ th symbol of user 2. The improved one-shot multiuser detector (IOS-MUD) converts asynchronous CDMA system to synchronous one by taking a window of length T_r as shown in Fig. 1.b. The resulting performance is not satisfactory, because it exploits only partial information of the user spreading waveforms, which results in degraded signal-to-noise ratio (SNR) performances [5], [13].

An efficient solution to this problem can be found in using sliding-window technique with expanded processing window length such that at least one symbol of each user can be included in the window. The processing window length that satisfies this condition is " P ", where $P=2, 3, 4, \dots$ symbols. As shown in Fig.1.c, the sliding-window MUD processes the received signal over a processing-window of length " P ", from $(n-1)T_s$ to $(n-1+P)T_s$, to detect $(n+m)$ th symbol, where $m \in [0, P-2]$, and consequently $(P+1)$ MF outputs are generated for each user's path. For K

users, L paths, $(P+1)KL$ MF outputs are utilized at the multiuser detection process.

Fig. 2 shows the structure of the sliding window MUD of length PT_r . It consists of $(P+1)$ MF banks, each MF bank is composed of KL MFs, multiuser filter and K maximum ratio combiners.

4. MULTIUSER DETECTORS IN MULTIPATH FADING CHANNELS.

There are two approaches which may be employed for MUDs. Multiuser filtering can take place either after multipath combining (post-combining), or prior to it (pre-combining). Performance differences of the two structures for decorrelating MUD in a known fixed channel have been compared in [14]. Multipath combining prior to multiuser filtering makes channel estimation more difficult since the multiuser detection depends on channel estimates, which cannot be estimated at the output of the detector in this case. Therefore, the practical implementations of the multiuser receivers first perform multiuser detection and, subsequently, channel estimation [15]. Such receivers also

have the advantage that the detection does not depend on the fading channel state.

As shown in Fig.2, at the middle banks (from 2nd bank to Pth bank), the received signal is matched-filtered by corresponding spreading sequences with one entire symbol duration. The MF output vector of these banks is

$$y^{(n+m)} = \int_{-\infty}^{\infty} S^{T(n+m)} r(t) dt$$

$$= R(-1)h^{(n+m+1)} + R(0)h^{(n+m)} + R(1)h^{(n+m-1)} + W^{(n+m)} \quad (10)$$

where $m \in \{0, p-2\}$. In the first MF bank, the received signal $r(t)$ is matched-filtered by a set of partial spreading sequence waveforms (*tail portions*) and they are expressed as

$$\tilde{S}_k^{(n)} = \begin{cases} S_k(t-(n-1)T_s - \tau_{k,l}); & (n-1)T_s \leq t \leq (n-1)T_s + \tau_{k,l} \\ 0 & ; \text{ otherwise} \end{cases} \quad (11)$$

where \sim denotes tail portion. The MF using *tail portions* is called a partial MF. This partial MF output vector is expressed as

$$\tilde{y}^{(n-1)} = \int_{-\infty}^{\infty} \tilde{S}^{T(n-1)} r(t) dt$$

$$= \tilde{R}(-1)h^{(n)} + \tilde{R}(0)h^{(n-1)} + \tilde{W}^{(n-1)}, \quad (12)$$

where $\tilde{S}^{(n-1)} = [\tilde{S}_{1,1}^{(n-1)} \tilde{S}_{1,2}^{(n-1)} \dots \tilde{S}_{K,L}^{(n-1)}]$,

$$\tilde{R}(0) = \int_{-\infty}^{\infty} \tilde{S}^{T(n-1)}(t) \tilde{S}^{(n-1)}(t) dt$$

$$\text{and } \tilde{W}^{(n-1)} = \int_{-\infty}^{\infty} \tilde{S}^{T(n-1)}(t) W(t) dt$$

The term $R(1)h^{(n-2)}$ is absent because $h^{(n-2)}$ is outside the processing window. Similarly, at the $(P+1)$ th MF bank, the received signal $r(t)$ is matched-filtered by (*a head portions*) of spreading sequence waveform defined as

$$\hat{S}_k^{(n+p)} = \begin{cases} S_k(t-(n+p-1)T_s - \tau_{k,l}); & (n+p-2)T_s + \tau_{k,l} \leq t \leq (n+p-1)T_s \\ 0 & ; \text{ otherwise} \end{cases} \quad (13)$$

where $\hat{\sim}$ denotes head portion.

The output of this MF bank is

$$\hat{y}^{(n+p-1)} = \int_{-\infty}^{\infty} \hat{S}^{T(n+p-1)} r(t) dt$$

$$= \hat{R}(0)h^{(n+p-1)} + \hat{R}(1)h^{(n+p-2)} + \hat{W}^{(n+p-1)} \quad (14)$$

where $\hat{S}^{(n+p-1)} = [\hat{S}_{1,1}^{(n+p-1)} \hat{S}_{1,2}^{(n+p-1)} \dots \hat{S}_{K,L}^{(n+p-1)}]$,

and $\hat{R}(0) = \int_{-\infty}^{\infty} \hat{S}^{T(n+p-1)}(t) \hat{S}^{(n+p-1)}(t) dt$. For convenience, the matched filter banks output vector may be expressed as follows:

$$Y_p = [\tilde{y}^{(n-1)} \quad y^{(n)} \quad y^{(n+1)} \dots \quad \hat{y}^{(n+p-1)}]^T$$

$$= \int_{-\infty}^{\infty} S_p^{T(n)} r(t) dt \quad (15)$$

$$= R_p h_p + W_p$$

where $S_p^{(n)} = [\tilde{S}^{(n-1)} \quad S^{(n)} \quad S^{(n+1)} \dots \quad \hat{S}^{(n+p-1)}]^T$,

$$R_p = \begin{bmatrix} \tilde{R}(0) & R(-1) & 0_{K,L} & 0_{K,L} & \dots & 0_{K,L} \\ R(0) & R(0) & R(-1) & 0_{K,L} & \dots & 0_{K,L} \\ 0_{K,L} & R(0) & R(0) & R(-1) & \dots & 0_{K,L} \\ \vdots & \vdots & \vdots & \vdots & \ddots & R(-1) \\ \dots & 0_{K,L} & 0_{K,L} & \dots & \dots & \hat{R}(0) \end{bmatrix}$$

$h_p = [H^{(n-1)} \ H^{(n)} \ H^{(n+1)} \ \dots \ H^{(n+P-1)}]^T$, and $W_p = [W^{(n-1)} \ W^{(n)} \ W^{(n+1)} \ \dots \ W^{(n+P-1)}]^T$, where 0_{kl} is a $KL \times KL$ null matrix.

In conventional RAKE detector, any symbol in the processing window from n th symbol to $(n+P-2)$ th symbol can be detected by making the decision on the combined output data of user k , $b_{ek}^{(n+m)} = \text{sgn}[C_k^{H(n+m)} y_k^{(n+m)}]$. (16)

Since there are nonzero *off-diagonal* terms in R_p , the MAI and consequently NF problem exist in the output.

To overcome these shortcomings, the outputs of the matched filter banks are fed to a multiuser filter to form a multi-user detector. Important linear multi-user detectors are decorrelating detector and LMMSE detector.

A. Decorrelating Detector.

Decorrelating detector provides NF resistance performance by eliminating MAI. To eliminate MAI, the MF output vector is fed to a decorrelating filter, in which the input signal is multiplied by the inverse of the cross-correlation matrix over the processing-window [16], [17].

The decorrelator output vector is $x_p^{(n+m)} = T_p^{(n+m)} R_p^{-1} Y_p = h_p^{(n+m)} + Z_p^{(n+m)}$, (17)

Where $x_p^{(n+m)} = [x_{p1}^{(n+m)} \ x_{p2}^{(n+m)} \ \dots \ x_{pK}^{(n+m)}]^T$, $x_{pk}^{(n+m)} = [x_{pk,1}^{(n+m)} \ x_{pk,2}^{(n+m)} \ \dots \ x_{pk,l}^{(n+m)}]^T$, $T_p^{(n+m)} = [0_{KL \times KL(m+1)} \ I_{KL} \ 0_{KL \times KL(P-m-1)}]$ and I_{KL} is a $(KL \times KL)$ identity matrix. A selector matrix $T_p^{(n+m)}$ is used to select $(n+m)$ th complete symbol in the processing window, where m is an integer ranging from 0 to $(P-2)$ and output noise vector $Z_p^{(n+m)}$ is Gaussian since it is a linear transformation of Gaussian noise W_p and the output noise covariance matrix is expressed as

$$E[Z_p^{(n+m)} Z_p^{H(n+m)}] = \sigma^2 T_p^{(n+m)} R_p^{-1} T_p^{T(n+m)}. \quad (18)$$

The decorrelator output vector has KL elements. There are L elements for each user which are associated with L resolvable independently faded paths. These L elements are coherently combined to form a decision statistic $b_{ekd}^{(n+m)}$ for user k as follows

$$b_{ekd}^{(n+m)} = \sum_{l=1}^L x_{p(k,l)}^{(n+m)} c_{k,l}^{*(n+m)}, \quad (19)$$

B. LMMSE Detector.

The target of LMMSE detector is to minimize the cost function $E\{|h_p - h_{pc}|^2\}$ where $h_{pc} = LY_p$ is the estimate of h_p . This leads to the LMMSE detector $L_M = (R_p + \sigma^2 \Sigma_{h|h}^{-1})^{-1}$, (20)

where $\Sigma_{h|h} = E\{h_p h_p^H\}$.

The selected LMMSE output vector is

$$x_{p,MMSE}^{(n+m)} = T_p^{(n+m)} L_M Y_p = M^{(n+m)} h_p + L_M^{(n+m)} W \quad (21)$$

where $x_{p,MMSE}^{(n+m)} = [x_{p1,MMSE}^{(n+m)} \ x_{p2,MMSE}^{(n+m)} \ \dots \ x_{pL,MMSE}^{(n+m)}]^T$,

$$x_{pL,MMSE}^{(n+m)} = [x_{pL1,MMSE}^{(n+m)} \ x_{pL2,MMSE}^{(n+m)} \ \dots \ x_{pLl,MMSE}^{(n+m)}]^T,$$

$$L_M^{(n+m)} = T_p^{(n+m)} L_M \quad \text{and}$$

$$M^{(n+m)} = L_M^{(n+m)} R_p = T_p^{(n+m)} L_M R_p.$$

The output noise vector can be expressed as follows $Z_{p,MMSE}^{(n+m)} = L_M^{(n+m)} W_p$, (22)

with covariance matrix

$$E\{Z_{p,MMSE}^{(n+m)} Z_{p,MMSE}^{H(n+m)}\} = \sigma^2 L_M^{(n+m)} R_p L_M^{H(n+m)}, \quad (23)$$

The L resolvable paths of each user are coherently combined to form decision statistics $b_{ck,MMSE}^{(n+m)}$ for user k as follows

$$b_{ck,MMSE}^{(n+m)} = \sum_{l=1}^L x_{p,MMSE}^{(n+m)} c_{k,l}^{*(n+m)}, \quad (24)$$

5. PERFORMANCE ANALYSIS.

The performance of the decorrelating and LMMSE detectors is analy-

zed in a known channel to obtain an expression for the average bit error probability (BEP) of each receiver. The analysis is based on the characteristic function method presented in [10], [14], and [18]. The characteristic function is solved via eigenanalysis for the matrix formed from the decision variable.

A. Decorrelating Detector Performance.

The decision statistic of the decorrelating receiver for user k after maximal ratio combining can be expressed in the form $b_{ckd}^{(n+m)} = C_k^{H(n+m)} x_{pk}^{(n+m)}$, (25)

includes the decorrelating filter output vector for user k . Eq. (25) can be re-writing in quadratic form as follows

$$b_{ckd}^{(n+m)} = v^H Q v. \quad (26)$$

where $Q = \frac{1}{2} \begin{bmatrix} 0_{l_i} & I_{l_i} \\ I_{l_i} & 0_{l_i} \end{bmatrix}$ and $v = [c_k^{(n+m)} \ x_{pk}^{(n+m)}]^T$

The probability of bit error for user k can be expressed as [10], [14].

$$P_{ck} = \sum_{i=1}^{2L} \prod_{\substack{j=1 \\ j \neq i}}^{2L} \frac{1}{1 - \lambda_i / \lambda_j} \quad (27)$$

where λ_i , $i, j = 1, 2, 3, \dots, 2L$ are the eigenvalues of the matrix $\beta_v Q$, and

$$\beta_v = E[v v^H] = \begin{bmatrix} \beta_{c_i}^{(n+m)} & \beta_{c_i x_{pk}}^{(n+m)} \\ \beta_{c_i x_{pk}}^{(n+m)} & \beta_{x_{pk}}^{(n+m)} \end{bmatrix}, \quad (28)$$

is the covariance matrix of the vector v . The combining vector covariance matrix is

$$\beta_{c_i^{(n+m)}} = \text{diag} \left\{ E \left[|c_{k,1}^{(n+m)}|^2 \right], E \left[|c_{k,2}^{(n+m)}|^2 \right], \dots, E \left[|c_{k,L}^{(n+m)}|^2 \right] \right\}. \quad (29)$$

The covariance matrix between the combining vector and the decorrelating filter output vector becomes

$$\beta_{c_i^{(n+m)}, x_{pk}^{(n+m)}} = A_k b_k^{(n+m)} \beta_{c_i^{(n+m)}}, \quad (30)$$

and the covariance matrix of the decorrelating filter output vector has the form

$$\beta_{x_{pk}^{(n+m)}} = A_k^2 \left(b_k^{(n+m)} \right)^2 \beta_{c_i^{(n+m)}} + \sigma^2 \left(T_p^{(n+m)} R_p^{-1} T_p^{(n+m)} \right)_{(a,a)}, \quad (31)$$

where a is the matrix identifier $a = (k-1)L + 1 : kL$.

B. LMMSE Detector Performance.

The decision statistic of the LMMSE detector for user k can be expressed as $\hat{b}_{k,MMSE}^{(n+m)} = C_k^{(n+m)} x_{pk,MMSE}^{(n+m)}$ (32)

and can be rewriting in quadratic form as follows $\hat{b}_{k,MMSE}^{(n+m)} = U_M^H Q U_M$. (33)

The receiver output vector $x_{pk,MMSE}^{(n+m)}$ is conditioned on the data vector $b_p = [b^{l(n-1)} \ b^{l(n)} \ b^{l(n+1)} \ \dots \ b^{l(n+p-1)}]^T$, so the probability of error for user k conditioned on b_p can be expressed as [10]

$$P_{e,k|b_p} = \sum_{\lambda^{(0)}}^{2L} \prod_{i=1}^{2L} \frac{1}{1 - \frac{\lambda_i}{\lambda}} \quad (34)$$

Where $\lambda_i, \ i, j = 1, 2, 3, \dots, 2L$ are the eigenvalues of the matrix $\beta_{v_{ki}} Q$ and

$$\beta_{v_{ki}|b_p} = \begin{bmatrix} \beta_{c_i^{(n+m)}} & \beta_{c_i^{(n+m)}, x_{pk}^{(n+m)}|b_p} \\ \beta_{c_i^{(n+m)}, x_{pk}^{(n+m)}|b_p} & \beta_{x_{pk}^{(n+m)}|b_p} \end{bmatrix} \quad (35)$$

is the covariance matrix of the vector v_{ki} . The combining vector covariance matrix is $\beta_{c_i^{(n+m)}}$.

The covariance matrix between the combining vector and the LMMSE filter output vector becomes

$$\begin{aligned} \beta_{c_i^{(n+m)}, x_{pk}^{(n+m)}|b_p} &= A_k \begin{bmatrix} 0_{(L-(k-1)L)} & b_k^{(n)} \sum_{l=0}^{n-1} v_{l,1}^{(n+m)} & 0_{(L-(K-1)L)} \\ 0_{(L-(k-1)L)} & b_k^{(n)} \sum_{l=0}^{n-1} v_{l,2}^{(n+m)} & 0_{(L-(K-1)L)} \\ \vdots & \vdots & \vdots \\ 0_{(L-(k-1)L)} & b_k^{(n+p-1)} \sum_{l=0}^{n+p-1} v_{l,1}^{(n+m)} & 0_{(L-(K-k)L)} \end{bmatrix} M^{(n+m)}, \end{aligned} \quad (36)$$

and the covariance matrix of the LMMSE filter output vector has the form

$$\beta_{x_{pk}^{(n+m)}|b_p} = M_k^{(n+m)} \sum_{l=0}^{n+m} M_k^{(n+m)} + \sigma^2 T_k^{(n+m)} R_p^{-1} T_k^{(n+m)} \quad (37)$$

where $M_k^{(n+m)} = T_{pk}^{(n+m)} M^{(n+m)}$ and $T_{pk}^{(n+m)} = \begin{bmatrix} 0_{L \times (k-1)L} & I_{L \times L} & 0_{L \times (K-k)L} \end{bmatrix}$

The k th user's average BEP of a LMMSE is obtained by averaging over all possible interfering symbol combinations. Thus, the BEP of user k can be expressed in the form [10], [14]

$$P_{e,k} = \frac{1}{|\Xi|^{2K-1}} \sum_{\substack{b_p \in \Xi^{2K} \\ b_k^{(n+m)}=1}} P_{e,k|b_p} \quad (38)$$

6. NUMERICAL RESULTS.

The performances of decorrelating and LMMSE receivers are analyzed and compared to the performance of the conventional RAKE receiver which is designed to combat multipath while ignoring the MAI. The channel characteristics are assumed to be known. Data symbols are BPSK-modulated and spread using gold sequences with period 63. A randomly chosen delay in the range $[0, T_s)$ was used, while keeping a uni-form distribution. The Doppler power spectrum is assumed to be Jake's spectrum with vehicle speed of 60 mph, carrier frequency 900 MHz, and data rate 9600 bps. The maximal ratio combining is used for diversity combining. In the analysis we take 20 active user and multipath diversity reception with 2 branches.

Bit error probabilities (BEPs) of detecting $(n+m)$ th symbol of user k using decorrelating detector with window length of $6T_s$ as a function of SNR are shown in Fig. 3. It is shown that the BEPs of n th and $(n+4)$ th symbols are not satisfactory compared to other medial symbols in the window.

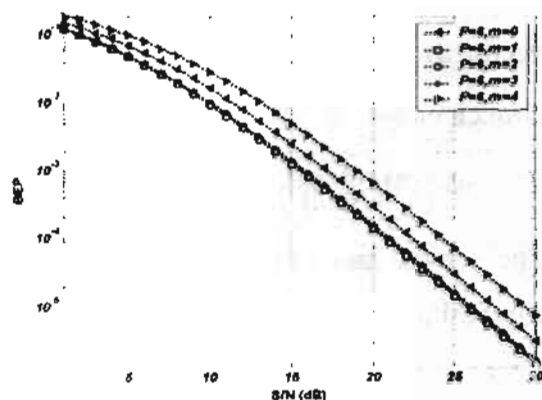

Fig.3 BEPs of detecting symbol $(n+m)$, $P=61$, $m=0,1,2,3,4$ using Decorrelating detector, $K=20$, $L=2$

This is because the n th symbols suffer from partial correlation between $(n-1)$ th partial symbols, also $(n+4)$ th symbols suffer from partial correlation between $(n+5)$ th partial symbols.

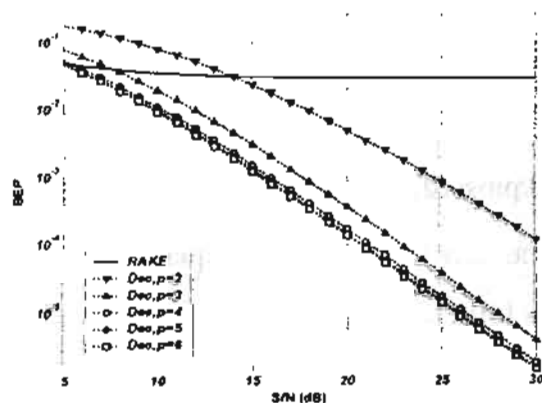

Fig.4 BEPs of RAKE detector and Decorrelating detector, $P=2, 3, 4, 5, 6$, $K=20$, $L=2$

Fig. 4 shows that the proposed decorrelating detector outperforms conventional RAKE detector and also shows the BEP improvement due to increment of window length "P".

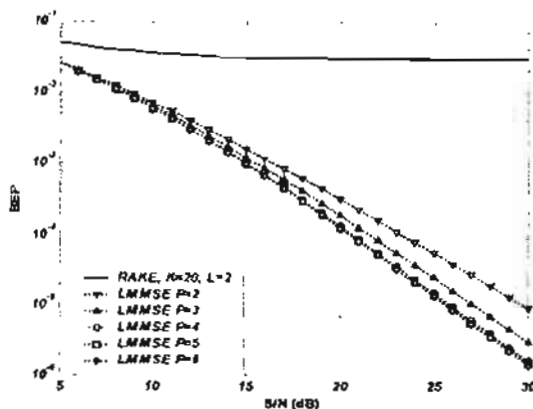

Fig.5 BEPs of RAKE detector and LMMSE detector. P=2, 3, 4, 5, 6, K=20, L=2

Fig. 5 compares between the BEPs of LMMSE detector and RAKE detector. This figure shows the performance improvement due to the increment of "P".

From fig.4 and fig.5 it can be shown that the performance of decorrelating and LMMSE detectors will be marginally improved with processing-window length up to four symbols.

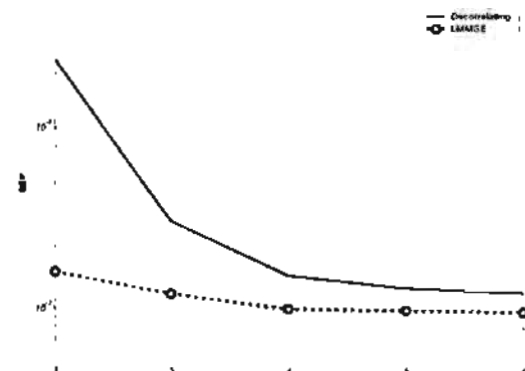

Fig.6 BEP of the decorrelating and LMMSE detectors Vs. P. K=25, L=2 and SNR=15dB

Fig.6 shows the BEP of the decorrelating and LMMSE detectors as a function of window length at signal to noise ratio

S/N= 25 dB and confirms that the BEP is seen to decrease as the window length increases. This figure shows that a marginal performance improvement can be achieved by expanding the window length from $2T_s$ to $4T_s$. It is also shown that the window length expansion of more than $4T_s$ does not exhibit a performance improvement.

Fig.7 shows the BEPs performance of decorrelating, LMMSE (with $P=4$) and RAKE detectors. It is shown that LMMSE detector is better than the decorrelating and RAKE detectors from BEP point of view when all users have equal SNRs. It is also shown that the BEPs of decorrelating and LMMSE detectors are approximately equal at high signal-to-noise ratio. This is because the noise effect becomes significantly small compared to MAI.

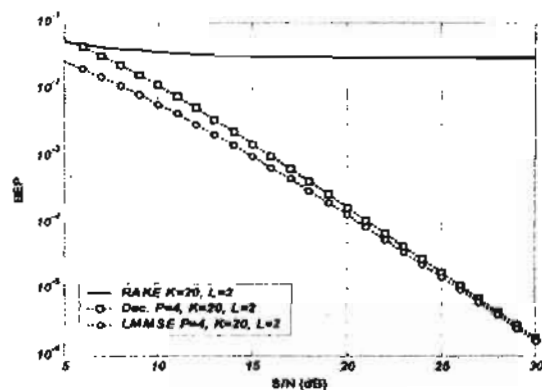

Fig.7 BEPs of the decorrelating, LMMSE detector (P=4Ts) and RAKE detectors, K=20, L=2

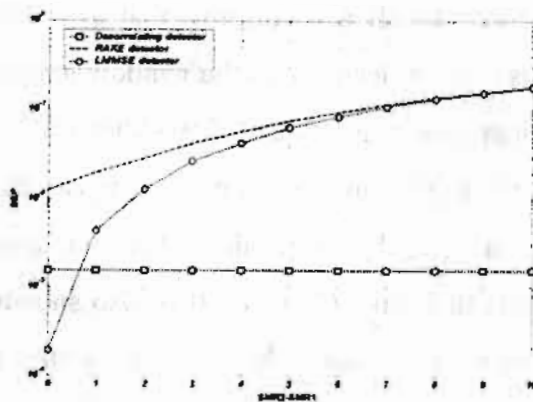

Fig.8 BEPs of the decorrelating, LMMSE detector ($P=4T_s$) and RAKE detectors Vs. SNR_2-SNR_1 , $K=2$, $L=2$, $SNR_1=15\text{dB}$

Fig. 8 shows the interfering power effect on the BEP of RAKE, Decorrelating ($P=4T_s$) and LMMSE ($P=4T_s$) detectors in uplink receivers. For simplicity, we suppose only 2 users, 2 paths for each user and SNR of the first user is 15 dB. This figure shows that only the decorrelating detector has the NF resistance and it superior to both LMMSE and RAKE detectors when the interfering user power exceeds the desired user power.

7. CONCLUSIONS

In this paper, sliding window approach is applied on both decorrelating and LMMSE detectors with expanded window length. Both detectors have a BEP performance

improvement when " $P=4T_s$ ". The decorrelating receiver eliminates MAI, while LMMSE receiver still suffers from MAI and consequently NF problem. Although LMMSE detector BEP performance outperforms decorrelating detector when all users have equal SNRs, decorrelating detector has NF resistance better than LMMSE detector.

REFERENCES

1. Ramjee Prasad, and Tero Ojanpera, "An overview of CDMA evolution toward wideband CDMA" IEEE Communication Surveys, Forth Quarter 1998 Vol. 1, No.1.
2. Markku J. Juntti, Behnaam Aazhang, "Finite memory-length linear multiuser detection for asynchronous CDMA communications", IEEE Trans. Commun., Vol.45, No. 5, pp. 611-622, May 1997.
3. Seung Joo Maeng, Byeong Gi Lee " Extended-window decorrelating detector for asynchronous CDMA channels and performance analysis", IEEE Trans. Commun., Vol.49, No. 1, pp. 35-40, January 2001.
4. Ruxandra Lupas, Sergio Verdu, "Near-far resistance of multiuser detector in asynchronous channels", IEEE Trans. Commun., Vol.38, No. 4, pp. 496-508, April 1990.
5. M. Peng, Y. J. Guo and S. K. Barton, "One-shot linear decorrelating detector for asynchronous CDMA", IEEE, pp. 1301-1305, May 1996.

6. Timo Laakso. "Receiving method and receiver ", United states patent, No. 6,011,812. Jan.2000.
7. Maria Missiroli, Yingjie Jay Guo and Stephen K. Barton "Near-Far Resistant Channel Estimation for CDMA Systems Using the Linear Decorrelating Detector", IEEE Trans. Commun. Vol.48 No.3 March.2000.
8. Hongbin Li, Jian Li, "Differential and coherent decorrelating multiuser receivers for space-time-coded CDMA systems", IEEE Trans. On signal processing. Vol.50, No. 10, pp. 2529-2536, October 2002.
9. John G. Proakis, "Digital communications". International Edition 2001.
10. Markku J. Juntti, Matti Latva-aho, "Bit-error probability analysis of linear receivers for CDMA systems in frequency-selective fading channels". IEEE Trans. Commun.. Vol.47, No. 12, pp. 1788-1791, December 1999.
11. Jerry D. Gibson, "The Mobile Communication Handbook" second edition, CRC Press LLC, 1999.
12. Theodore S. Rappaport, "Wireless communications", Uppre Saddle River, New Jersey. 1999.
13. David Hertz, Harvey J. Greenberger, "Asynchronous CDMA decorrelating detector", United states patent, No. 5,917,829. Jun.1999.
14. Matti Latva-aho, "Bit-error probability analysis for FRAMES WCDMA Downlink receivers", IEEE Trans. Vehicular Tech., Vol.47, No. 4, pp. 1119-1131, Nov 1998.
15. Markku J. Juntti, "Multiuser demodulation for DS-CDMA systems in fading channels", Ph.D. dissertation Univ. Oulu, Oulu, Finland, 1997.
16. Xiaofeng Wang, Wu-Sheng Lu, and Andreas Antoniou, "An overlapping window decorrelating multiuser detector for DS-CDMA radio channels", IEEE Trans. Commun., Vol.49, No. 8, pp. 1488-1494, August 2001.
17. Zoran Zvonar, David Brady, "Linear multipath-decorrelating receivers for CDMA frequency-selective fading channels", IEEE Trans. Commun., Vol.44, No. 6, pp. 650-653, June 1996.
18. Michael J. Barrett, "Error probability of optimal and suboptimal quadratic receivers in rapid rayleigh fading channels", IEEE Journal on Selected Area in Comm. Vol.SAC.5 No.2 Feb.1987.