

Assessment of Farm Residuals Uniformity within a Spherical Mixer to Accelerate Conversion to Compost

Ismail, Z. E. ; A. M. Tharwat and Mayada M. Radwan
Agric. Eng. Dept., Fac. of Agric., Mansoura Univ.



ABSTRACT

This study aimed to determine the best parameters suitable to mix agriculture residues to produce compost in short time. A spherical mixer was designed to determine the optimum operating levels. The spherical shape ensures the regularity of the residue components movement inside it and also, it assures move the all sphere component, it easy to clean, to fill and unload. It is consists of four parts namely; body of spherical mixer–frame–transmission system–source of power. To prepare the compost raw materials, the shredded maize stover, poultry litter and clipping grass were collected to mix. The mixer fills by each raw material according to the determined ratio. The studied variables are three level of spherical rotating speed (25, 35 and 45rpm), three level of mixing time (900, 1800, 2700 and 3600 sec) and three levels of filling mass (24.3; 32.5 and 36.5 kg). To test the mixing operation, the ash percentage was identified. For each test the eleven samples were taken from the different location of the spherical mixer. Each test replicates three times and statistically analysis. It may be concluded that the percentage of ash decreased with increasing each of the amount of material in the spherical mixer and mixing time and vice versa for mixer rotational speeds. By comparing the calculated values of ash percentage (11.59%) with the experimental ash values for mixed under above conditions may be indicated that the treatment of 1800s with 36.5kg and 25rpm is the best parameters gives a good ash distribution.

INTRODUCTION

The first step, to conform the wastes elements to benefit materials as compost, is that reducing its size and set its compounds in best mixing conditions. There are many methods for mixing equipment, including horizontal and vertical agitated chambers, tumbling vessels, and pressure air agitated processes. Mixing can be continuous or batch operation, but delivering the components and removing the product are often more critical than the choice of mixing equipment. For solids mixing there are some of the key issues such as proper mix time, mixer volume, scheduling and surge, segregation, and feeding, especially in the case of continuous mixing (Clark, 2009).

Several authors have cited mixing time as a critical element to get equiponderant mixes (Harner *et al.*, 1995; Groesbeck *et al.*, 2004; Behnke, 2005 and Biermann, 2008). On the other hand, Oelberg (2015) investigated and developed an on-farm system to assess total mixing ratio (TMR) consistency along the feed bunk and to evaluate mixer performance. Implementation of this system has improved TMR consistency on many dairy farms. The standard for TMR particle size consistency determined on 10 samples with the coefficient of variation (CV) of 2.5% or less for particles retained on the middle screen and pan of the state particle separator (PSPS). Ismail, (2002) identified the general theoretical equations describing the mixing speed of particles in vessel are conformed in two levels during the motion of mixed material. Mixture conditions, mixed speed, and agitated mass in vessel are carried out to evaluate the performances of rotating mixer. To prepare the best mixture conditions, it is recommended to keep the friction angle of mixer and blade resting angle on mixing shaft in the range from 18 to 25o. Generally, the increase in mixing blade radius increases the amount of agitated mass in vessel, consequently improving the mixing efficiency at all variable under study. The mixed mass speed at the first level is directly proportional to mixing blade radius. Increasing the mixing blade radius from 10 to 15 cm increases the mixing blade speed about 1.59 % at index-

$Z < 1$ and 0.6 % at index- $Z > 1$ and mixing speed ($n=30rpm$). While at $n=120 rpm$ the above relationship is 14.85 % and 7.60 % at index- $Z < 1$ and index- $Z > 1$ respectively. Also, Ismail, (2001) reported that the best mixing efficiency (98, 96.8 and 99 %) with the lowest energy consumption (1.77, 1.53 and 0.51 kWh/ton) at the three rations containing wastes of haricot, okra and pea by using the mixing unit were at speed of 90 rpm, mixing time of 420s and impeller angle of 10 degree.

The elementary comparison for effect of rotation axis and loading pattern on the mixing performances for a cylindrical vessel moving according different motions such as rotating drum and hoop mixer filled with spherical particles were identified by Marigo (2012), and added that an exponential was done to describe the mixing behavior in terms of a characteristic number of rotations to achieve mixing. The expected for the rotating drum operating in rolling mode that the axial mixing is purely a dispersive mechanism and the radial mixing is dominant. With the hoop mixer, he observed that the rocking motion causes mixing in the axial direction and that, the overall mixing efficiency depends on the operating speed. The axial mixing in case of a hoop mixer improves with the speed whereas the radial mixing slightly degrades as the speed increases. It observed that a decrease in mixing efficiency from 23 to 46 rpm and a subsequent increase as speed increases from 46 to 69 rpm for both axial and radial mixing. Fairfield *et al.* (2005) conducted that mixing times depend on the type of mixer that is being used and whether it is a dry or a wet mixture.

Mixing is one of the most critical operations. Factors such as equipment type/condition, ingredient size, and mix time can significantly alter the uniformity of the mixed product (Jared 2012). From above researches, most of them carried out the experiments on horizontal or vertical agitated chambers or on tumbling vessels or on pressure air agitated processes or on cylindrical vessel. Nevertheless, no one approved experiments on spherical mixer. Therefore, the aim of this work is to design, construct and test the spherical mixer to mixes the farm residuals and to determine the

optimum operation condition such as number of sphere revolution, mixing time and filling volume.

MATERIALS AND MBTHODS

To meet the practical objectives of this work a series of experimental tests were carried out on the investigated spherical mixer that design, constructed and formed at workshop of Agriculture Engineering Department, Mansoura University.

Spherical mixer components

Mainly, the spherical mixer as shown in Fig (1) involves a spherical shape (1), cover (2), transmission system (3), motor (4) and frame (5).

Spherical shape: many attempts conducted to construct the sphere because of many conditions and requirements must be available within the design such as;

The designed unit must have an ability to distribute light and heat regularly.

These units have an ability to revolve around its axis under the condition that gave the best regularity of components distribution during preparing the compost.

A four of plate iron rings, of one meter diameter and with 16 and 6 mm width and thickness respectively, were welded together to conform special shape. The outer cover of the sphere is two layers of plastic sheet with a thickness of 200 μ .

The gross dimension of ball is 100 cm in diameter, with a net volume of 0.536m³. The ends of the ball are connected with two discs (25 cm diameter and 5 mm thickness). Each disc was welded with iron shat of 254mm diameter that connected with bearing that fixed on the main frame. Inside the sphere a four steel wings were fixed under the condition of move the material in loose motions.

Frame: The construction of frame consists of two parts. The first one is designed to set the ball axis on two bearing with main dimensions of 120 × 100 × 100 cm height, width and length respectively. The second parts intended to fix the transmission system. The frame is made of steel angles with 30 × 30mm and with 160 × 60 × 100 width, height and length respectively.

Transmission unit: The sphere taken its motion from electrical motor (1.5 hp-1.12kW at 1400 rpm) and the transmission was done by using a set of gears and chains. A gear -box with reduction ratio of (1 to 10) was set to reduce the motor revolution and at same time change the direction of motion from vertical to horizontal. By changing the gear teeth number, it is easy to get different speeds as shown in Fig. (2).

Electrical circuits: A simple electrical circuits was done on the investigated mixer to allow the mixer to turn a certain time with clockwise and anticlockwise.

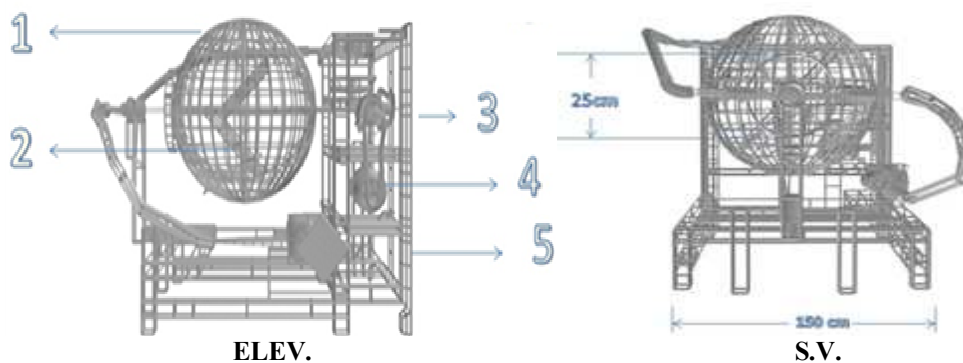

Fig. 1. Spherical mixer components

- 1- Spherical shape 2- Impeller 3- Transmission system 5-Frame 4- Motor

N.B.

The Y1-Y1 is the vertical axis in elevation position and Y2-Y2 is vertical axis in side view position.

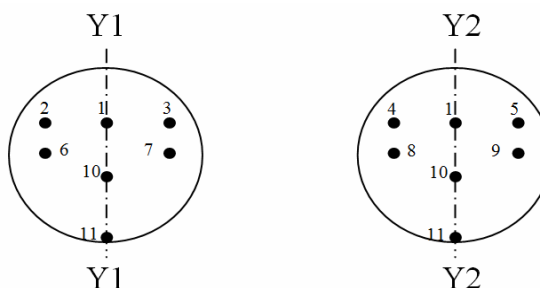

Fig. 2. Location of ash measuring points

The raw materials: Three types of row materials are investigated under this study. Maize stover was used as one of the raw materials for composting media. This materials was collected from crops farm of faculty of Agric., Mansoura Univ. it was shredded using shredding machine to cut maize stover into small size. It is taken motion from electrical motor of 5.0hp (3.73kW) with 1420 rpm. The second row material was poultry litter. It collected and moved from poultry farm of Damietta governorate. Grass was the third row material.

It collected and moved from gardens of Mansoura University.

Many in-door experiments were conducted to judge, what is the best number of sphere rotation that gives the similar sample of mixer? Then at supply the mixer of residuals (with weight ratio of two weight unite of maize stover : three and half weight unit of clipping grass : one weight unite of poultry litter) inside the sphere.

The residuals ash percentage from the experimental of spherical mixer is identified under:

1. Three rotational speed (25; 35 and 45 rpm)
2. Four working times (900; 1800; 2700 and 3600 s) half of each working time is rotated in counter clockwise (C.C.O) and the other clockwise (C.O) around the "X" axis of sphere mixer.
3. Three levels amount of filling materials are 24.28; 32.50 and 36.50 kg that represent of 50; 67 and 75% from total sphere volume. Each filling one include the same content ratio (2.0 : 3.5 : 1.0 from maize stover : clipping grass : poultry litter respectively).

To evaluate the quality of mixed material, as shown in Fig. (2), the 11 points were fixed its location inside the spherical mixer. These locations were distributed to overcome all void point of spherical place.

The sample from these locations was collected and the percentage of ash was determined. Crude ash content estimated according to AOAC (1970) for each sample and dried in an oven at 65°C for 72 h to complete the additional analysis. The dry samples were taken from each treatment and 2 g weighted for each into porcelain crucible and place in muffle furnace preheated to 600°C. It remains at this temperature 2h with automatic control pyrometer. Transfer crucibles directly to cool and weight immediately, calculate ash % to first decimal place as:

$$\text{Crude ash content (\%)} = \frac{\text{dry sample mass} - \text{ash sample mass}}{\text{dry sample mass}} \times 100$$

(AOAC, 1970)

RESULTS AND DISCUSSION

To study the condition that recognize best regularity of components distribution during preparing the compost on investigated spherical mixer the distribution of ash percentage in two perpendicular levels in 'Y' axis were investigated. Each level have "7" location points. The place of these point locations are fixed under all different measurements.

Ash percentage in level Y1Y1

The percentage of ash during 25 rpm mixer revolution for different location points (1; 4; 5; 8; 9; 10 and 11) and different working times (900; 1800; 2700 and 3600s) under filling sphere size relative to mass of 24.28; 32.50 and 36.50 kg is illustrated in Fig. (3). Regarding to Fig (3-A), the ash percentage have a range from 9.65% to 16.74% for different point locations at sphere filling of 24.28 kg. However, it recorded 14.72% to 16.60% at 32.5 kg and from 11.07% to 13.11% at 36.5kg filling sphere. From the above results, it may be concluded that the percentage of ash increased with increasing the amount of material at first stage (from 24.28 to 32.5kg) then decreased at second step (from 32.5 to 36.5kg). It may be due to the centrifugal force make the largest piratical distributed outside the center of mixer. The same tendency was found at increasing the mixing times. However, the rate of decrement change from 1800s (Fig. 3-B) to 2700s (Fig 3-C) and from 2700 to 3600s (Fig 3-D). By comparing the calculated values of ash percentage (11.59%) as the best homogeneous values for mixed material with the

experimental ash values under above conditions, the results indicated that the treatment of 1800s; 36.5kg and 25rpm is lie in around recommended ash percentage as shown in Fig. (3-B2).

The percentage of ash during mixer revolution of 35rpm for different location points (1; 4; 5; 8; 9; 10 and 11) and different working times of 900; 1800; 2700 and 3600s under filling sphere size relative to mass of 24.28; 32.50 and 36.50 kg is illustrated in Fig. (4). Regarding to Fig (4-A), the ash percentage have a range from 8.54% to 10.61% for different point locations at sphere filling of 24.28 kg. However, it recorded 9.44% to 12.49% at 32.5 kg and from 5.3% to 12.37% at 36.5kg filling sphere. From the above results, it may be concluded that the percentage of ash increased with increasing the amount of material at first stage then decreased at second. The same tendency was found at increasing the mixing times. However, the rate of decrement change from 1800s (Fig. 4-B) to 2700s (Fig. 4-C) and from 2700s to 3600s (Fig. 4-D).

As shown in Fig. (5), the percentage of ash during mixer revolution of 45rpm at different working times of 900; 1800; 2700 and 3600s under filling sphere size relative to mass of 24.28; 32.50 and 36.50 kg indicated that there were no clear trends for ash percentage at different location points (1; 4; 5; 8; 9; 10 and 11). Regarding to Fig (5-A), all the ash percentage for 7 location lies out the curve of calculated ash (11.59% recommended ash). The ash percentages have a range from 10.595% to 17.96% for different point locations at sphere filling of 24.28 kg. However, it recorded 10.24% to 13.81% at 32.5 kg and from 9.34% to 13.21% at 36.5kg filling sphere. The above results indicated that the percentage of ash decreased with increasing the amount of material in the spherical mixer. But, these trends were inversely relation at mixing times. However, the rate of decrement change from 1800s (Fig. 5-B) to 2700s (Fig. 5-C) and from 2700 to 3600s (Fig. 5-D).

Ash percentage in level Y2Y2

The percentage of ash during 25 rpm mixer revolution for different location points (1; 2; 3; 6; 7; 10 and 11) and different working times of 900; 1800; 2700 and 3600s under filling sphere size relative to mass of 24.28; 32.50 and 36.50 kg is illustrated in Fig. (6). regarding to Fig (6-A), the ash percentage have a range from 8.68 % to 17.65% for different point locations at sphere filling of 24.28 kg. However, it recorded 11.79% to 16.60% at 32.5 kg and from 11.21% to 16.75% at 36.5kg filling sphere. From the above results, it may be concluded that the percentage of increased with increasing the amount of material at first stage then decreased at second. The same trend was found at increasing the mixing times. However, the rate of decrement change from 1800s (Fig. 6-B) to 2700s (Fig. 6-C) and from 2700 to 3600s (Fig 6-D). By comparing the calculated values of ash percentage (11.59%) with the experimental ash values for mixed under above conditions may be indicated that the treatment of 1800s with 36.5kg and 25rpm is nearest at the all samples to the stander ash percentage as shown in Fig. (6-B2).

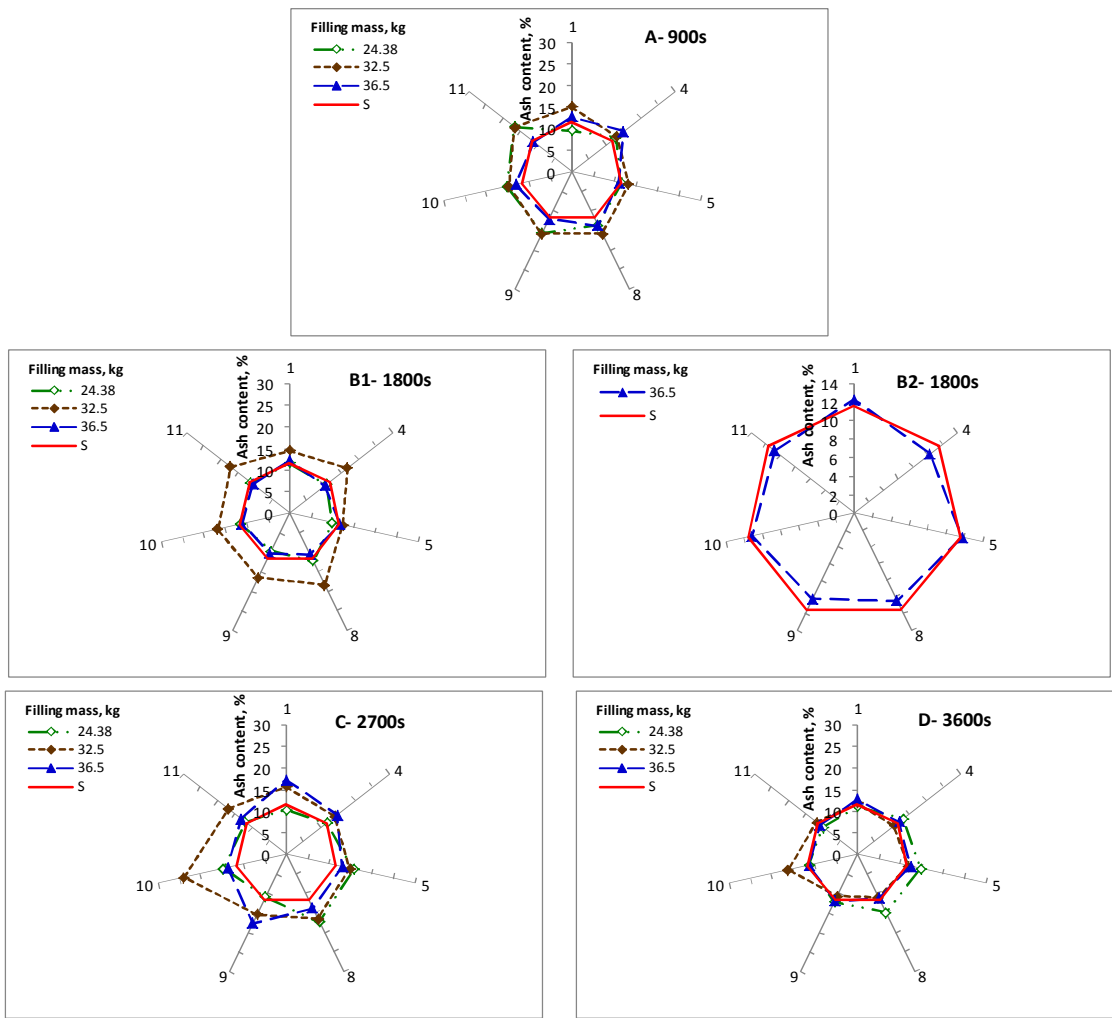

Fig. 3. The ash percentage at 25 rpm and different working times of 900; 1800; 2700 and 3600s

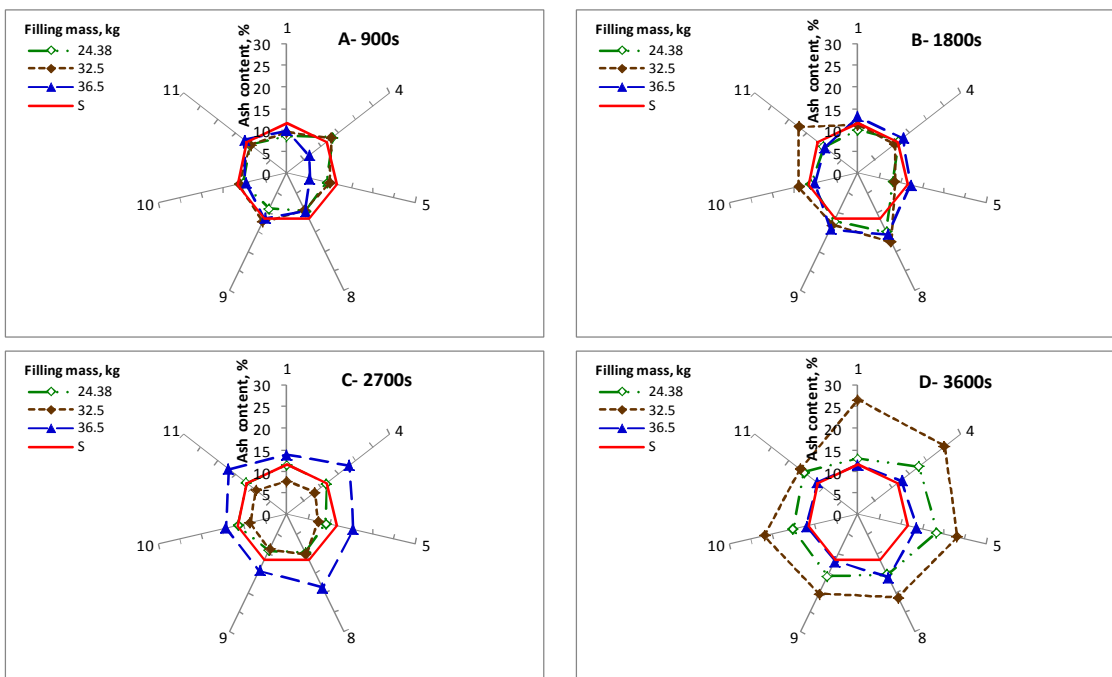

Fig. 4. The ash percentage at 35 rpm and different working times of 900; 1800; 2700 and 3600s

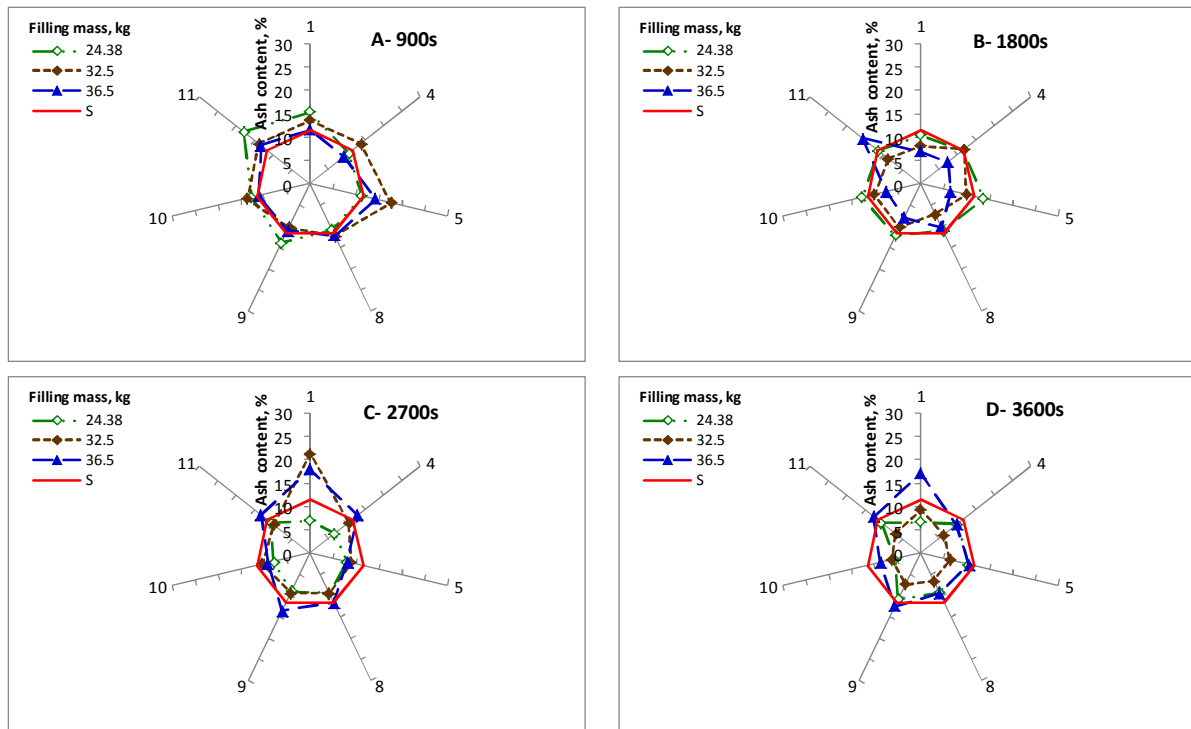

Fig. 5. The ash percentage at 45 rpm and different working times of 900; 1800; 2700 and 3600s

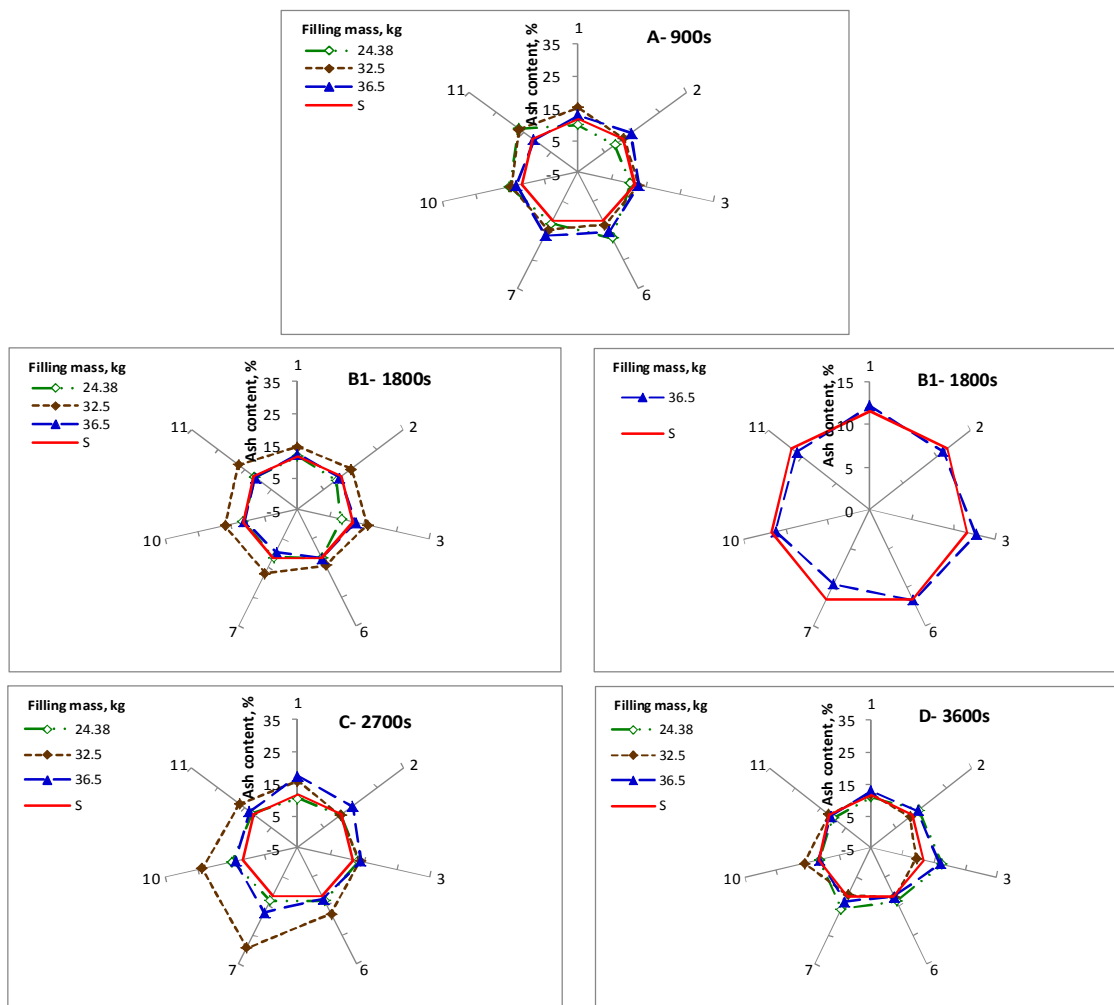

Fig. 6. The ash percentage at 25 rpm and different working times of 900; 1800; 2700 and 3600s

The percentage of ash during mixer revolution of 35rpm for different location points (1; 2; 3; 6; 7; 10 and 11) and different working times (900; 1800; 2700 and 3600s) under filling sphere size relative to mass of 24.28; 32.50 and 36.50 kg is illustrated in Fig. (7). Regarding to Fig (7-A), the ash percentage have a range from 8.54% to 10.61% for different point locations at sphere filling of 24.28 kg. However, it recorded 9.44% to 12.49% at 32.5 kg and from 5.45% to 12.37% at 36.5kg filling sphere. From the above results, it may be concluded that the percentage of ash increased with

increasing the amount of material at first stage then decreased at second. The same trend was found at increasing the mixing times. However, the rate of decrement change from 1800s (Fig. 7-B) to 2700s (Fig. 7-C) and from 2700s to 3600s (Fig. 7-D).

As shown in Fig. (8), the percentage of ash during mixer revolution of 45rpm at different working times of 900; 1800; 2700 and 3600s under filling sphere size relative to mass of 24.28; 32.50 and 36.50 kg indicated that there were no clear trends for ash percentage at different location points (1; 2; 3; 6; 7; 10 and 11).

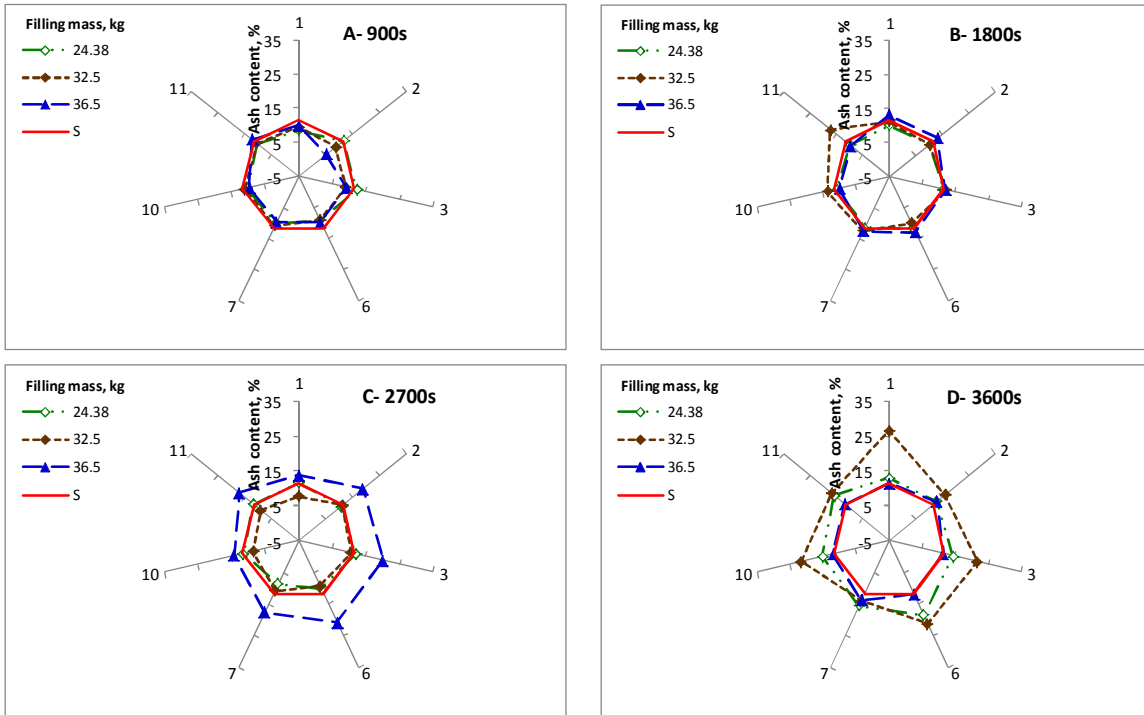

Fig. 7. The ash percentage at 35 rpm and different working times of 900; 1800; 2700 and 3600s

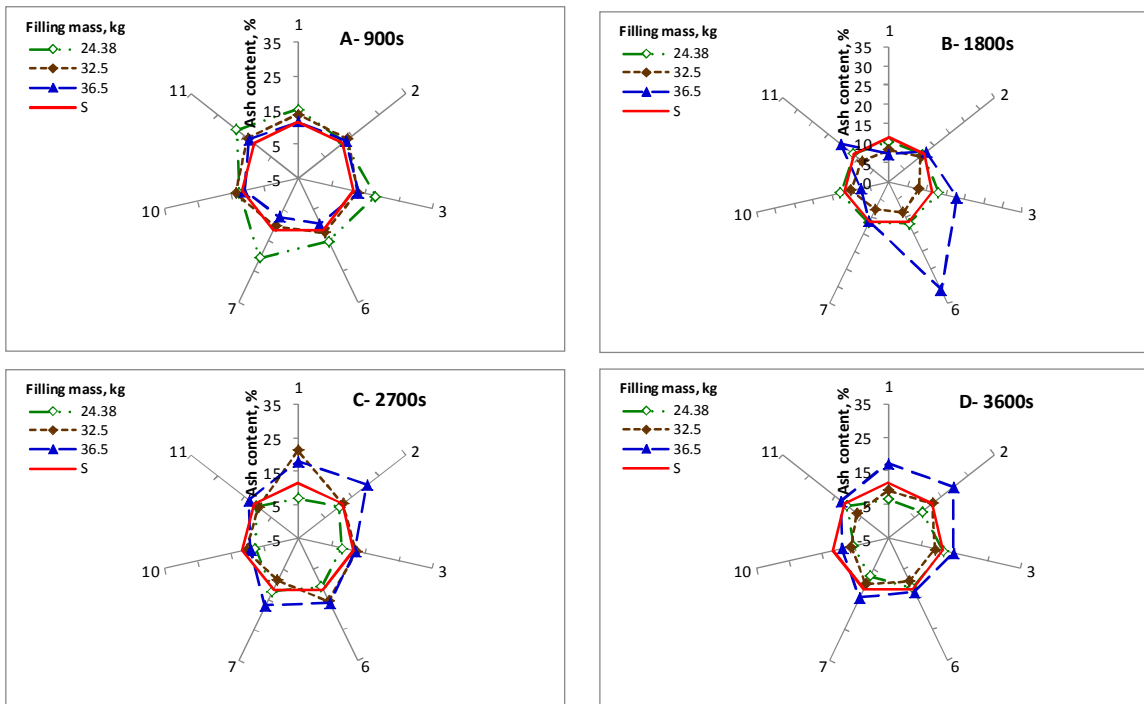

Fig. 8. The ash percentage at 45 rpm and different working times of 900; 1800; 2700 and 3600s

Regarding to Fig (8-A), all the ash percentage for 7 location lies out the curve of calculated ash. The ash percentages have a range from 12.01% to 20.58% for different point locations at sphere filling of 24.28 kg. However, it recorded 10.26% to 13.81% at 32.5 kg and from 9.66% to 13.21% at 36.5kg filling sphere. The above results indicated that the percentage of ash decreased with increasing the amount of material in the spherical mixer. But, these trends were inversely relation at increasing speed.

Mixer power consumption:

Figure (9) shows that the consumed power for mixing operation at mixer revolution of 25, 35 and 45 rpm and filling of sphere size relative to mass of 24.28, 32.50 and 36.50 kg. The figure cleared that the total power consumption un-significant increased by increasing mixer rotational speed from 0.952 to 0.998 and from 0.971 to 1.012 and from 0.972 to 1.041 kW at filling mass of 24.38; 32.5; 36.5 respectively. At the recommend operating parameters of 25 rpm, 1800s and 36.50 kg, the power consumption recorded 0.972kW.

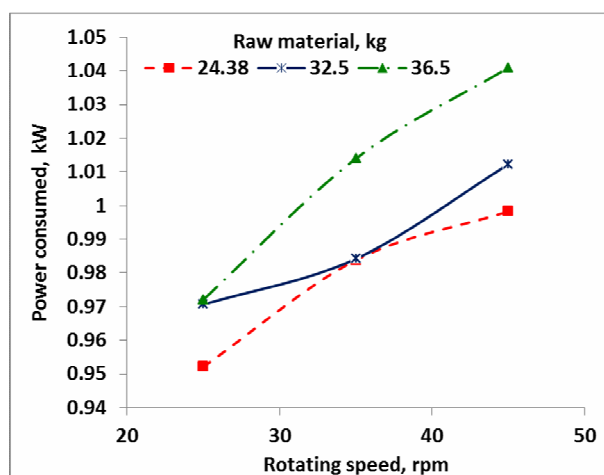

Fig. 9. The mixing consumption power at different raw material mass

CONCLUSION

From the results, it may be concluded that the optimum mixing speed of 25 rpm, mixing time 1800s and filling sphere size relative to mass of 36.50 kg presented the nearest parameters that compatible with the recommended ash percentage (11.59 %).

REFERENCES

- AOAC, 1970. Official methods of analysis 4th Ed. Association of Official Agricultural Chemists. Washington, D.C.
- Behnke, K.C. 2005. Mixing and uniformity issues in ruminant diets. Penn State Dairy Cattle Workshop, University Park, PA; pgs 39- 45.
- Biermann, S. 2008. Mixing integrity for ruminant diets containing by-products. Minnesota Nutrition Conf., University of Minnesota, St. Paul. 2008; pgs 145-159.
- Clark, J.P. 2009. Case studies in food engineering, Food engineering series. Springer Science Business Media, pp12.
- Fairfield, D.; H. Thomas; R. Garrison; J. Bliss; K. Behnke and A. Gilpin. 2005. Pelleting in feed manufacturing technology. Chapter 11. Pg. 142-167.
- Groesbeck, C.N.; R.D. Goodband; M.D. Tokach; S.S. Dritz; J.L. Nelssen and J.M.
- Harner, J.P.; K. Behnke and T. Herrman. 1995. Rotating drum mixers. MF-2053. Kansas State
- Ismail, N.K. 2001. Engineering studies on the processing of some agricultural wastes. Ph.D. Thesis Ag. Eng. Dept. Fac. of Ag. Mansoura Univ.
- Ismail, Z.E. (2002). The theoretical scope of a rotating agitator mixer to prepare the livestock alimentation. The 10th Annual conf. of the Misr of Ag. Eng., 16 – 17 October, Development of Ag. Eng. Tech. in The Arab and Islamic World, 81-94.
- Jared, R. 2012. Mixing: A Detailed Look at the Factors that Influence Mix Uniformity. Froetschner, M.Sc. Marketing Manager DSM Nutritional Products, Inc. Parsippany, NJ. pp18
- Marigo, M.; D.L. Cairns; M. Davies; A. Ingram; E.H. Stitt 2012. A numerical comparison of mixing efficiencies of solids in a cylindrical vessel subject to a range of motions. Powder technology, 217: 540 – 547.
- Oelberg, T.J. 2015. Effective outcomes of TMR audits. Tri-State Dairy Nutrition Conf., 122 - 132.
- Pfost, H.B. 1976. Feed Mixing. In: H.B. Pfost (Ed.), Feed Manufacturing Technology. AFMA, Arlington, VA. pp. 85.

تجانس مخلوط مخلفات المزرعة داخل خلاط كروي لتسريع تحويلها إلى كمبوست زكريا إبراهيم إسماعيل ، احمد ثروت محمد و ميادة ممدوح رضوان قسم الهندسة الزراعية – كلية الزراعة – جامعة المنصورة

تهدف هذه الدراسة إلى تجانس مخلوط مخلفات المزرعة داخل خلاط كروي لتسريع تحويلها إلى سماد عضوي (كمبوست) في أقل وقت حيث تم تصميم الخلاط على شكل كرة لما تتميز به من سهولة التعبئة والتفريغ والتنظيف مع ضمان التقلب الكامل للمكونات بداخلها. وهذا الخلاط مكون من أربع أجزاء الجسم الرئيسي للكرة والإطار ووحدة نقل الحركة ومصدر القدرة. ولإعداد الخليط تم حساب مكوناته التي تتناسب تركيب الكمبوست وكانت النسب المستخدمة 2.0 : 3.5 : 1.0 وحده وزنيه من حطب الذرة، ومخلف تقطيع النجيل وفرشة الدواجن لى التوالى. وقد اشتملت متغيرات التجارب على ثلاث سرعات للخلاط وهي (25,35,45 لفة/دقيقة)، ثلاث كميات تحميل للكرة (38,32.5,36.5 كجم)، وأربع أزمنة لخلط (900,1800,2700,3600 ثانية). ولتقييم عملية الخلاط تم أخذ 11 عينة من كل تجربة لتحديد نسبة الرماد ومقارنتها بنسبة الرماد لمخلوط المكونات المحسوب كمؤشر للخلاط الجيد وتبين من التجارب أن المعاملة 25 لفة/دقيقة وتحميل 36.5 كجم وزمن خلط 1800 ثانية هي انطب التجارب للخلاط الجيد.